

# A-2000 Perforated Pipe

## (4"-36" Diameter)

### The Exceptional Subdrainage System

#### Designed for Better Performance

Quality design and preferred materials selection make CONTECH® A-2000™ perforated pipe the designer's first choice for subsurface drainage materials. A-2000 double-wall PVC pipe will give you confidence in your drainage system's long-term performance capabilities.

#### Benefits by Design

- 46 psi pipe stiffness for assured deep trench performance and H-20 wheel loads at shallow covers.
- Glossy smooth (Manning's n = .009) interior for greater flow, flatter installation grades, smaller diameter requirements and less interior silting.
- Higher beam strength than HDPE underdrains for improved alignment and grade control during installation.
- Lightweight, long lengths with positive O-ring gasketed bell-spigot joints result in fast, easy, economical installation.
- Manufactured only from virgin, low-filler cell class PVC resin (12454 per ASTM D1784) for maximum durability.
- Straightness allows uniform slot positioning.
- Complete line of fittings for uniform quality and more efficient placement.

#### National Standards

Economical CONTECH A-2000 subdrainage pipe, available in 4" through 18" diameters in 12'-6" lengths and 21" through 36" diameters in standard 13'-0" lengths, conforms to the requirements of ASTM F949 and ASTM F794.

Slot geometry and placement provide a minimum of 1.90 square inches/lineal foot opening for each diameter. 20'-0" lengths of 4" and 6" are available on special order.

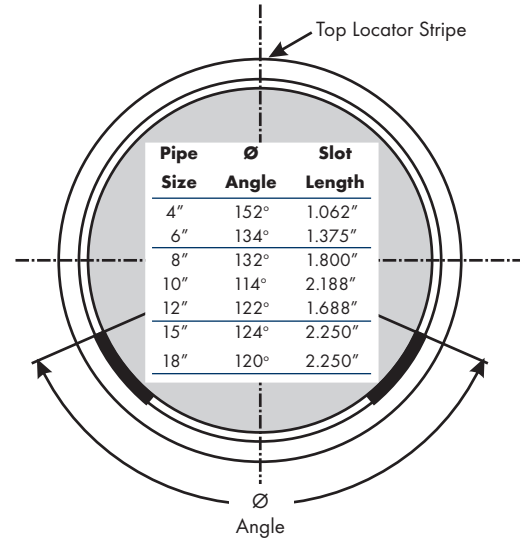

Perforation Dimensions				
Pipe Size	Slot Length	Slot Width	Slot Centers	Open Area*
4"	1-1/16"	.031"	.413"	1.90
6"	1-3/8"	.031"	.516"	1.98
8"	1-3/4"	.031"	.689"	1.90
10"	2-3/16"	.031"	.826"	1.98
12"	1-11/16"	.051"	1.033"	2.00
15"	2-1/4"	.051"	1.377"	2.00
18"	2-1/4"	.051"	1.377"	2.00

\* Open area is square inches per lineal foot of underdrain pipe.  
 Note: 21" through 36" is available with 3/8" diameter holes for open area specified by engineer.

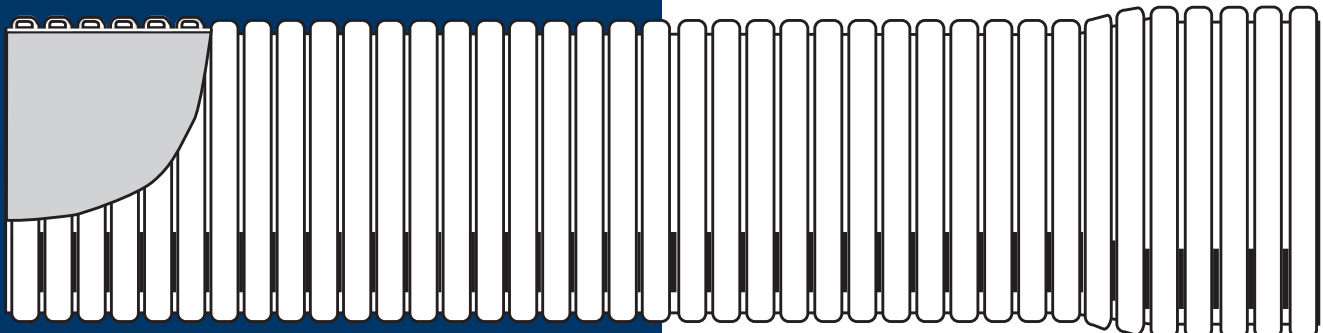

# Better Performance by Design

## Filter Performance

In soils or aggregates containing migratory fines, high-quality geotextile wraps are proven to be effective in protecting against inflow reductions and interior silting.

For best performance, the selected geotextile must have high resistance to blinding and clogging, while preventing significant passage of fines.

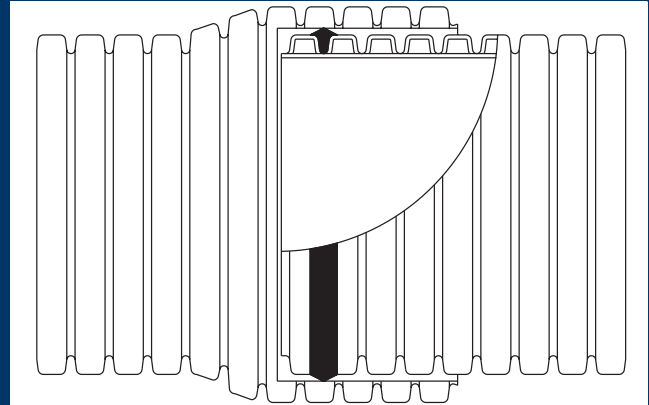

8" thru 36" is also available in fully-perforated pipe.

CONTECH Construction Products Inc. provides site solutions for the civil engineering industry. CONTECH's portfolio includes bridges, drainage, sanitary sewer, stormwater and earth stabilization products.

**For more information, call one of CONTECH's Regional Offices located in the following cities:**

<b>Ohio (Corporate Office)</b>	<b>513-645-7000</b>
California (San Bernardino)	909-885-8800
Florida (Tampa)	727-544-8811
Georgia (Atlanta)	770-409-0814
Indiana (Indianapolis)	317-842-7766
Kansas (Kansas City)	913-906-9200
Maryland (Baltimore)	410-740-8490
Ohio (Cincinnati)	513-645-7393
Oregon (Portland)	503-258-3180
Texas (Dallas)	972-590-2000

**Your Local Sales Office is:**

**Visit our web site: [www.contech-cpi.com](http://www.contech-cpi.com)  
1.800.338.1122**

NOTHING IN THIS CATALOG SHOULD BE CONSTRUED AS AN EXPRESSED WARRANTY OR AN IMPLIED WARRANTY OF MERCHANTABILITY OR FITNESS FOR ANY PARTICULAR PURPOSE. SEE CONTECH'S STANDARD QUOTATION OR ACKNOWLEDGEMENT FOR APPLICABLE WARRANTIES AND OTHER TERMS AND CONDITIONS OF SALE.



©2007 CONTECH CONSTRUCTION PRODUCTS INC.  
All rights reserved. Printed in USA.